

## Installation of optional e\*thirteen Lockring Dust Pocket

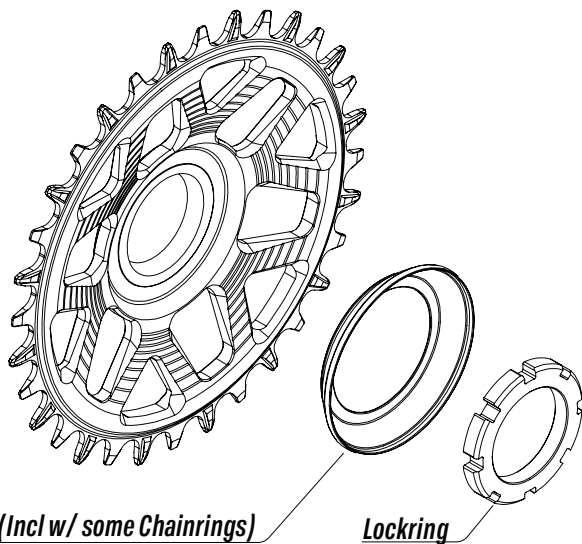

*Lockring Dust Pocket (Incl w/ some Chainrings)*

*Lockring*

### Note for Bosch™ Motors

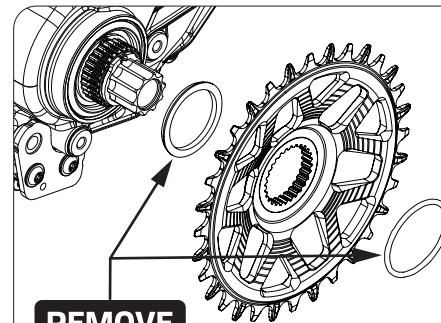

Please remove o-ring and/or spacer if present in Bosch™ assembly.

### NOTICE

- Refer to your bike manufacturer's chainline requirements.
- Torque lockring to your bike manufacturer's recommended specs prior to riding.

