

PREPARATION

E*THIRTEEN SIDEKICK HUB SERVICE KIT				
BEARING PRESS SCREW 	BEARING PRESS HANDLE 	UNTHREADED BEARING DRIFT 	SCREWS 	CLAWS
		THREADED BEARING DRIFT 	STOPPER 	WASHER

ADDITIONAL TOOLS			
PIN SPANNER 	TIRE LEVER 	ANGLED NEEDLE NOSE PLIERS 	6MM HEX TOOL
16mm/adjustable spanners are suitable alternatives			

BEARING SIZES	
6808 52 mm 40 mm 7 mm	6903 30 MM 17 mm 7 mm

LUBRICANTS AND RETAINING COMPOUNDS	
 RETAINING COMPOUND We recommend using a high strength, high viscosity, oil resistant methacrylate based retaining compound for bearing press-fits. For example Loctite® 638 or similar.	 GREASE We recommend grease with an NGLI grade 1 or 0, specifically for use with mountain bike or automotive bearings. For example Dumonde Tech Pro X Freehub Grease, Reach® 580, Slickoleum®, Buzzy's™ Slick-honey, SRAM® Butter, or similar.

DISASSEMBLY

FREEHUB REMOVAL

- HOLD drive side axle endcap and pull gently away from hub shell.
- PULL drive-side axle endcap gently, unscrew non-drive side endcap.
- SEPARATE non-drive side endcap, hub body and freehub.

XD™ DRIVER	Please note the bearing spacers in the following models	HG™ DRIVER
MICRO SPLINE DRIVER		MINI HG™ DRIVER
148 7-SPEED INTEGRATED CASSETTE		157 7-SPEED INTEGRATED CASSETTE

- APPLY light outward pressure on the spring tangs to release from the seating groove.
- SEPARATE spring from freehub body.

1. REMOVE the three pawls from the freehub body.

3X

6903 BEARING REMOVAL

- ASSEMBLE the required tools in the order shown above.
- TURN the bearing press screw by hand until resistance is felt.

- HOLD the bearing press handle securely.
- TURN the hex tool in the direction shown to press the 6903 bearing out of the hub shell.

- DISASSEMBLE tools by unscrewing from either end.
- REMOVE 6903 bearing and reducer.

- SEPARATE 6903 bearing from the reducer.

6808 BEARING REMOVAL

- LOCATE claws in gap between ratchet ring and bearing

Threaded Bearing Drift

- SCREW bolts through the threaded bearing drift and claws

- PLACE assembly on a stable work surface.
- HOLD the pin spanner securely.
- TURN the hex tool in the direction shown to pull the 6808 bearing out of the hub shell.

- REMOVE tool assembly and 6808 bearing from hub shell.
- REMOVE plastic bearing spacer.
- DISASSEMBLE tool assembly.

- APPLY upwards pressure on the bottom face of the ratchet ring using a tire lever or similar plastic prying tool.
- ROTATE the hub a few degrees.
- REPEAT steps 1 and 2, working around the ratchet ring until release.

Apply less pressure near release to avoid ejecting pins

- REMOVE ratchet ring.
- REMOVE all 6 locating pins.

6X

REASSEMBLY

RATCHET RING REASSEMBLY

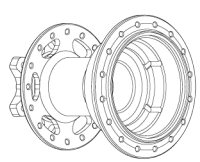
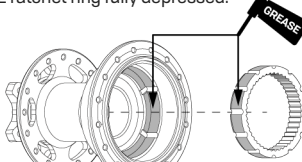
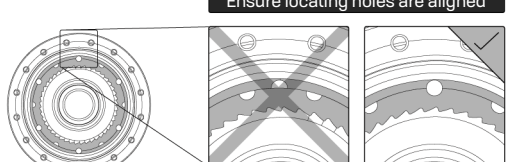
<ol style="list-style-type: none"> CLEAN residual grease and dust INSPECT hub shell for damage and wear 	<ol style="list-style-type: none"> GREASE mating surfaces of ratchet ring and hub shell. ENSURE locating holes. PUSH ratchet ring into hub body. APPLY even pressure, parallel with axis. ENSURE ratchet ring fully depressed. 	<p>Ensure correct ratchet tooth orientation</p> <p>Ensure locating holes are aligned</p>  <p>Using a locating pin can help align locating holes</p>
---	---	---

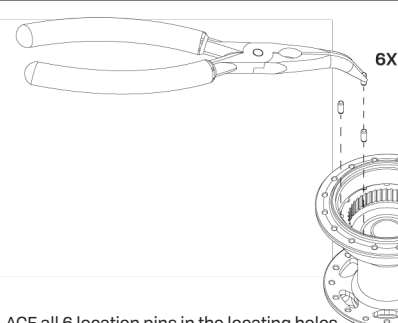
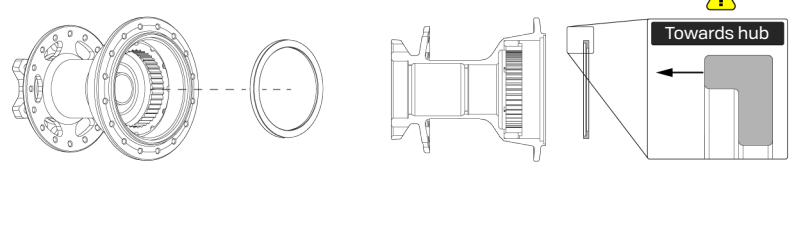
 <ol style="list-style-type: none"> PLACE all 6 location pins in the locating holes ENSURE pins are fully depressed 	<ol style="list-style-type: none"> INSTALL 6B08 plastic bearing shim  <p>Towards hub</p>
--	--

6B08 BEARING REASSEMBLY

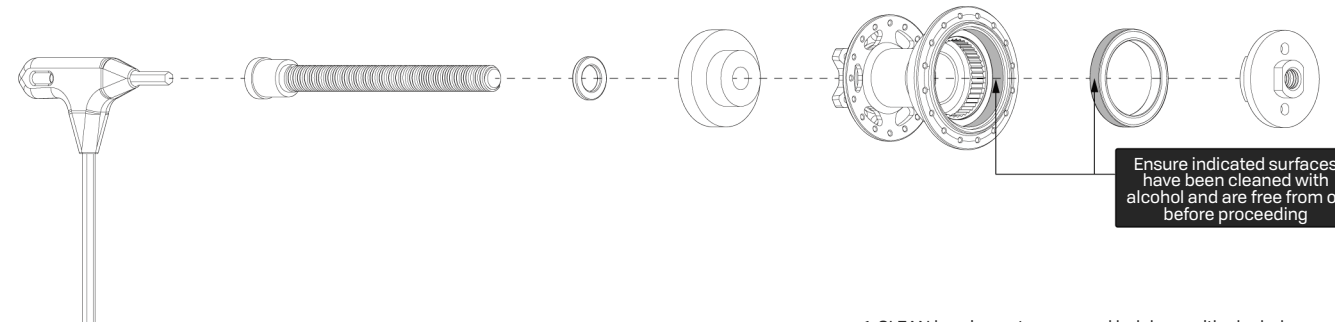
 <p>Ensure indicated surfaces have been cleaned with alcohol and are free from oil before proceeding</p> <ol style="list-style-type: none"> CLEAN bearing outer race and hub bore with alcohol. ASSEMBLE the required tools in the order shown above. TURN the bearing press screw by hand until resistance is felt

- ENSURE bearing is evenly seated around the full circumference of the hub.
- APPLY a 1-2mm thick strip of retaining compound all the way around the bearing.
- HOLD the hub shell securely.
- ROTATE the bearing press screw in the direction shown using the hex tool
- ENSURE bearing is fully seated.
- CLEAN any excess retaining compound on bearing face with alcohol.

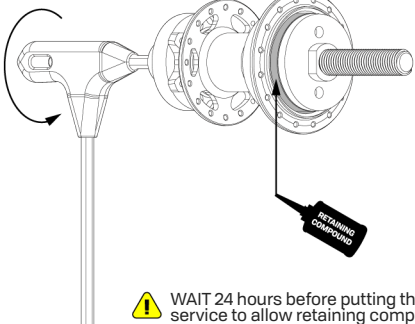

RETAINING COMPOUND

WAIT 24 hours before putting the wheel back in service to allow retaining compound to cure.

6903 BEARING REASSEMBLY

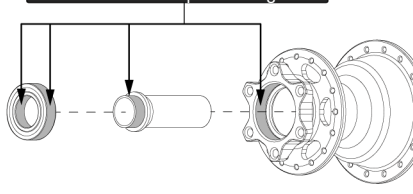
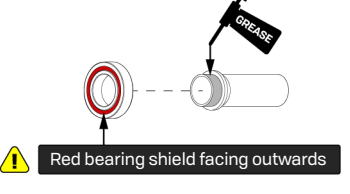
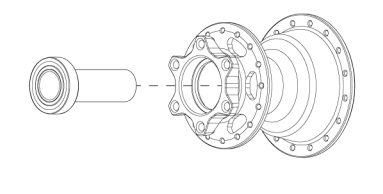
<p>Ensure indicated surfaces have been cleaned with alcohol and are free from oil before proceeding</p> 	<ol style="list-style-type: none"> APPLY grease to the reducer bearing contact face INSERT reducer into 6903 bearing <p>Red bearing shield facing outwards</p> 	<ol style="list-style-type: none"> INSERT reducer assembly partially into hub shell 
---	---	---

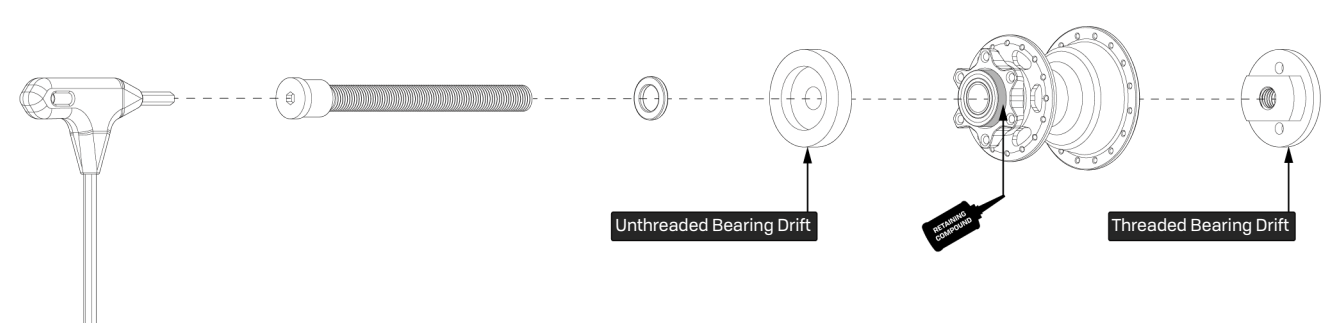
 <p>Unthreaded Bearing Drift</p> <p>Threaded Bearing Drift</p> <ol style="list-style-type: none"> ASSEMBLE tool kit in the order shown above. ROTATE the bearing press screw in the direction shown using the hex tool. APPLY a 1-2mm thick strip of retaining compound all the way around the bearing
--

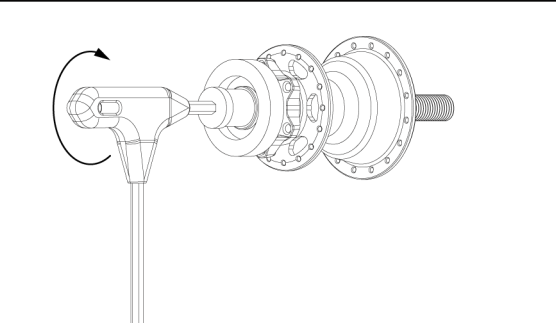
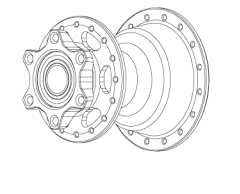
 <ol style="list-style-type: none"> HOLD the hub shell securely. ROTATE the bearing press screw in the direction shown using the hex tool. ENSURE bearing is fully seated. CLEAN any excess retaining compound on bearing face with alcohol. 	 <p>WAIT 24 hours before putting the wheel back in service to allow retaining compound to cure.</p>
---	---

FREEHUB REASSEMBLY

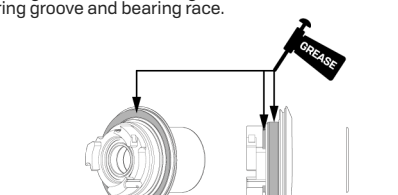
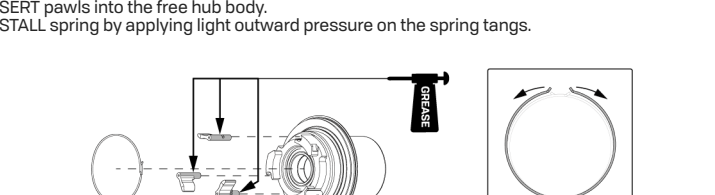
<ol style="list-style-type: none"> APPLY grease to the bearing seal, spring groove and bearing race. 	<ol style="list-style-type: none"> APPLY grease pawl axles. INSERT pawls into the free hub body. INSTALL spring by applying light outward pressure on the spring tangs. 
---	---

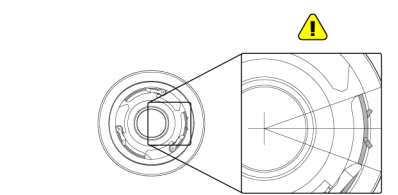
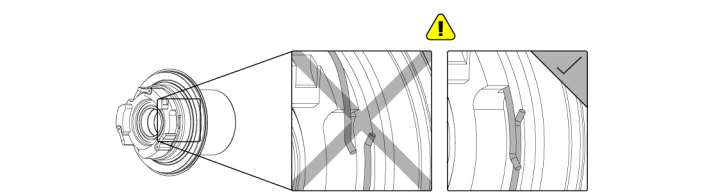
<ol style="list-style-type: none"> CENTER spring tangs between pawl and stopping boss. 	<ol style="list-style-type: none"> ENSURE spring is correctly seated in the grooves on the pawls and freehub body. 
---	--

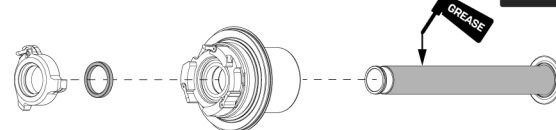
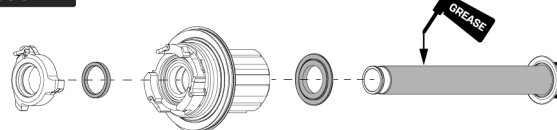
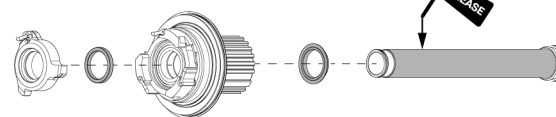
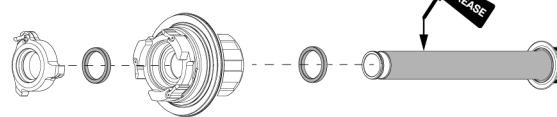
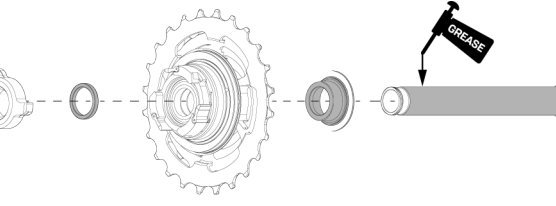
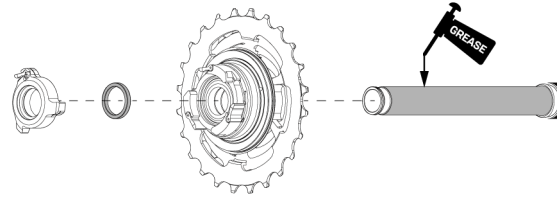
<p>XD[®] DRIVER</p> 	<p>HG[™] DRIVER</p> 
<p>MICRO SPLINE DRIVER</p> 	<p>MINI HG[™] DRIVER</p> 
<p>148 7-SPEED INTEGRATED CASSETTE</p> 	<p>157 7-SPEED INTEGRATED CASSETTE</p> 

Please note the bearing spacers in the following models

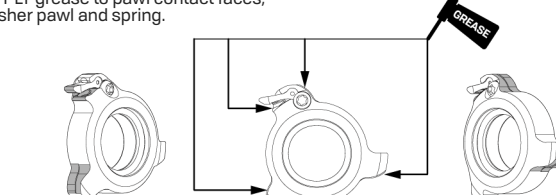
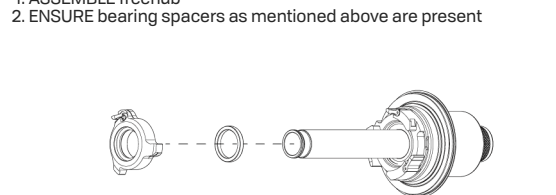
<ol style="list-style-type: none"> APPLY grease to pawl contact faces, pusher pawl and spring. 	<ol style="list-style-type: none"> ASSEMBLE freehub ENSURE bearing spacers as mentioned above are present 
---	--

DEADBAND ADJUSTMENT

(DEGREE OF ROTATION UNTIL PAWL ENGAGEMENT)

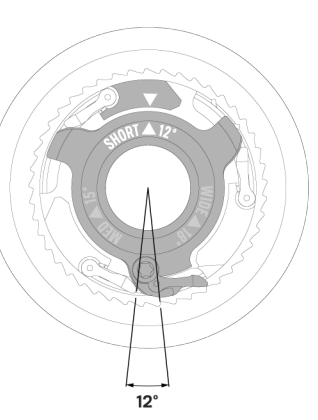
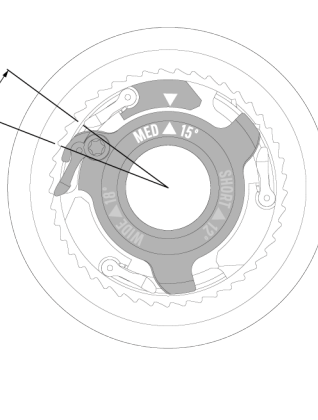
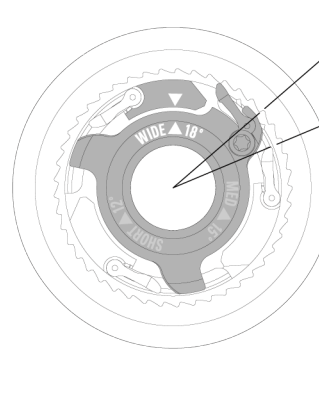
<p>SHORT - 12°</p>  <p>QUICKER PEDALING RESPONSE</p>	<p>MEDIUM - 15°</p> 	<p>WIDE - 18°</p>  <p>BETTER SUSPENSION PERFORMANCE</p>
---	--	---

HUB BODY REASSEMBLY

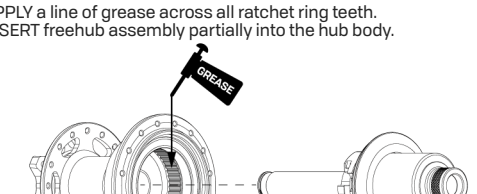
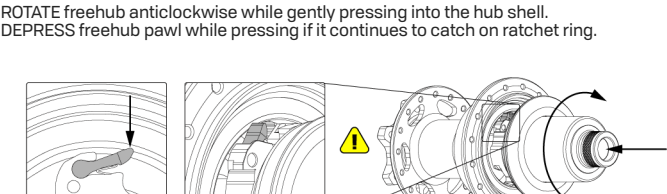
<ol style="list-style-type: none"> APPLY a line of grease across all ratchet ring teeth. INSERT freehub assembly partially into the hub body. 	<ol style="list-style-type: none"> ROTATE freehub anticlockwise while gently pressing into the hub shell. DEPRESS freehub pawl while pressing if it continues to catch on ratchet ring. 
---	--

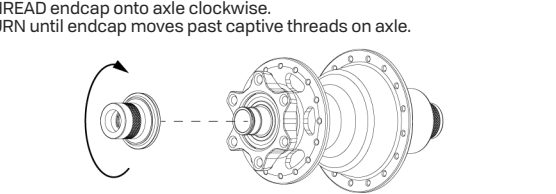
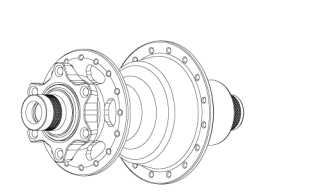
<ol style="list-style-type: none"> THREAD endcap onto axle clockwise. TURN until endcap moves past captive threads on axle.  <p>Note: A small amount of side-to-side axle play should be noted at this point</p>	 <p>Congratulations, you are all done! Now get out there and ride!</p>
---	--