

TRS & LG1 CRANKSETS REMOVAL

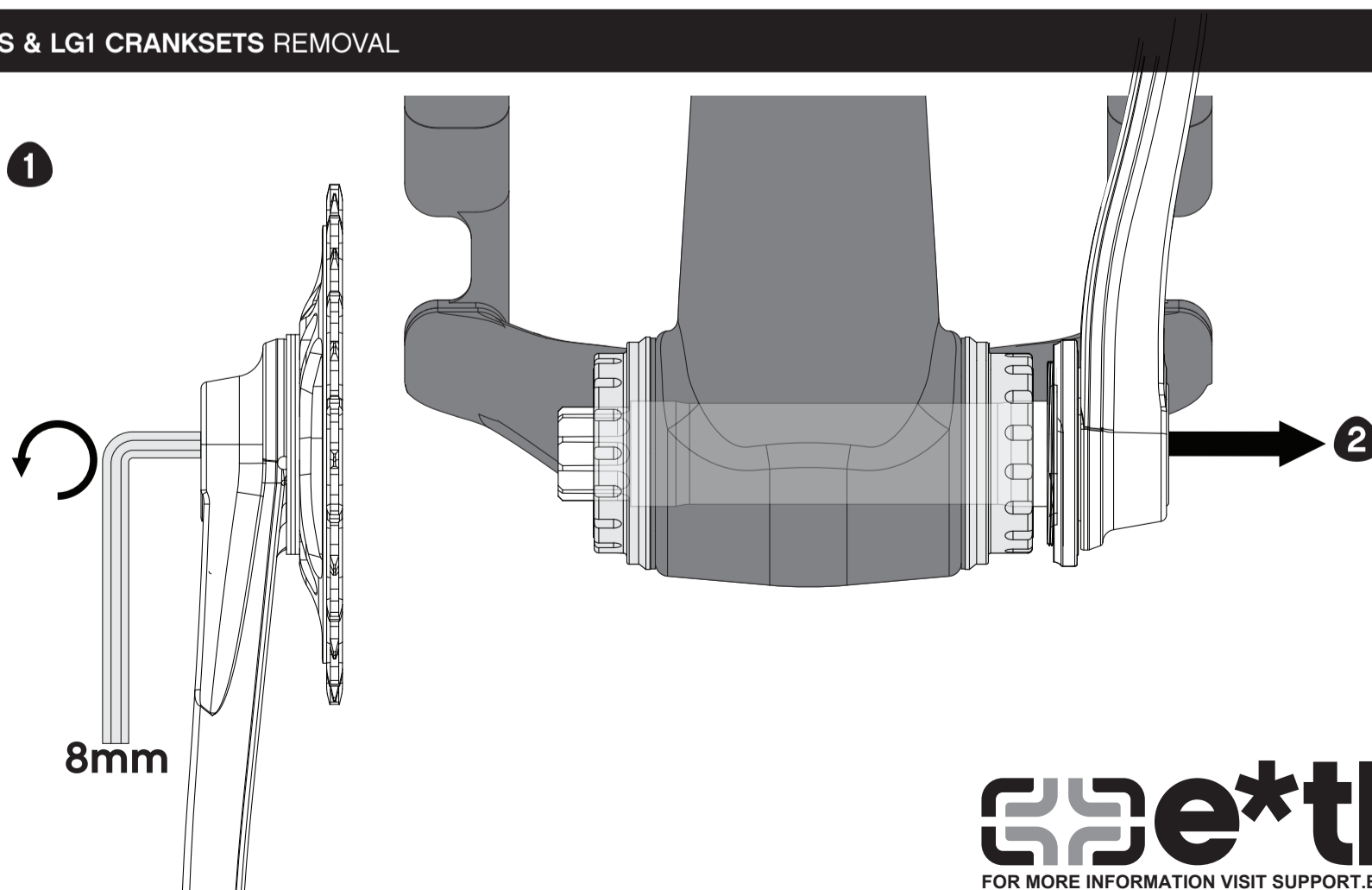

BASE BB92 INSTALL

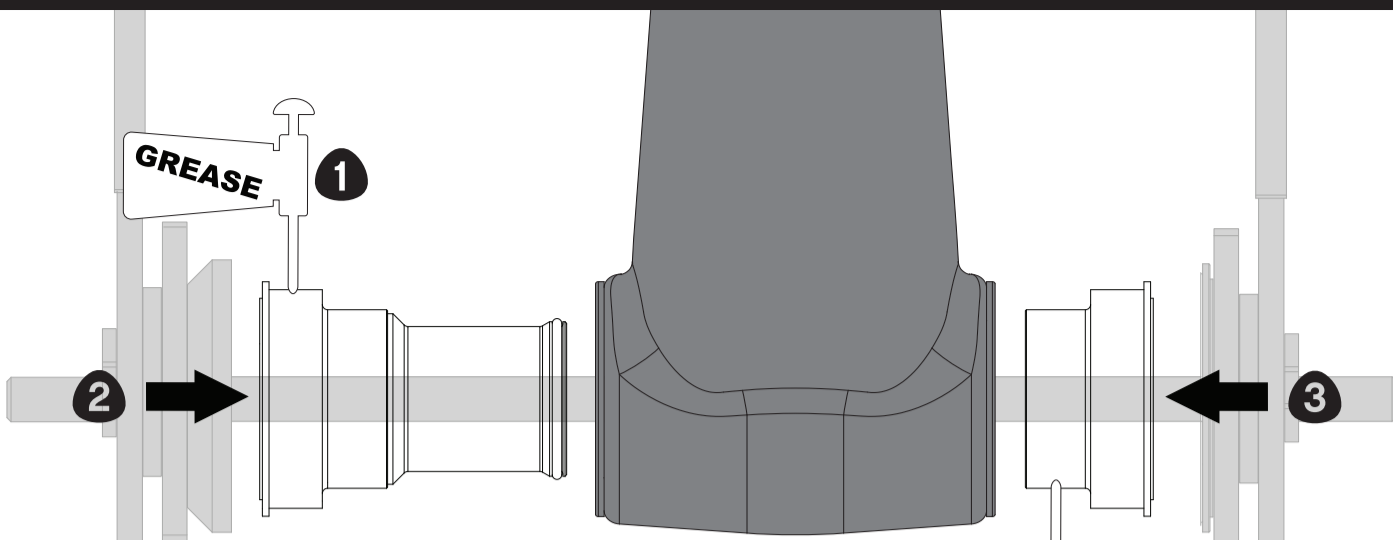

SPINDLE SPACER TABLE* BB92

Crankset	Spindle length	BB shell width	Non-drive side spacer	Drive side spacer
TRSr Carbon	123mm	92mm	0.5mm	0.5mm
TRS	113mm	92mm	0.5mm	0.5mm
XCX and 2015+ LG1	113mm	92mm	0.5mm	0.5mm
2014 and earlier LG1 only	113mm	92mm	1.5mm (1mm + 0.5mm)	4mm (3.5mm + 0.5mm)
TRS	113mm	89.5mm	0.5mm	3mm (3x 1mm)
TRSr Carbon	123mm	89.5mm	0.5mm	3mm (3x 1mm)
XCX and 2015+ LG1	113mm	89.5mm	0.5mm	3mm (3x 1mm)
LG1 cranks	123mm	107mm	0.5mm	0.5mm
LG1r Carbon	138mm	107mm	0.5mm	0.5mm
TRS Fatbike (73mm offset)	145mm	121mm	2mm (2 x 1mm)	2mm (2x 1mm)
TRS Fatbike (78mm offset)	155mm	121mm	7mm (2 x 1mm + 5mm)	7mm (2x 1mm + 5mm)
TRS Fatbike (78mm offset)	155mm	132mm	1.5mm (1mm + 0.5mm)	1.5mm (1mm + 0.5mm)

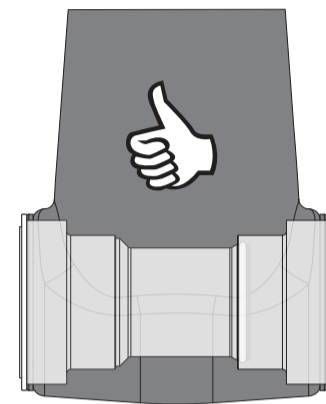
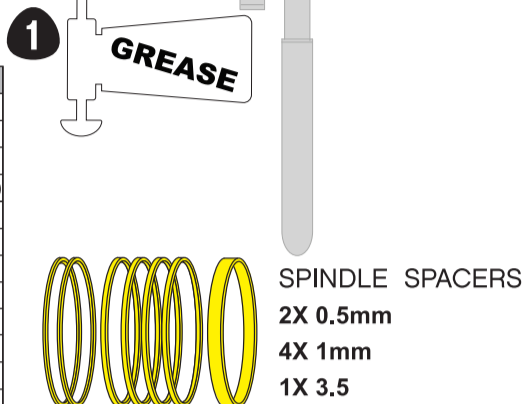

*Cranksets with "1 deg" marked on them are 2015+.

BASE PF30 INSTALL

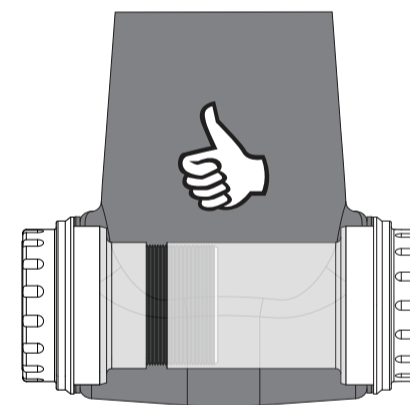
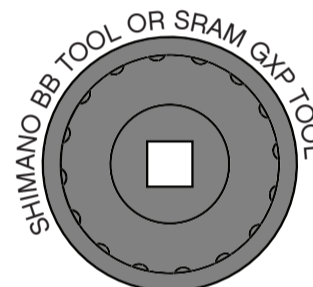
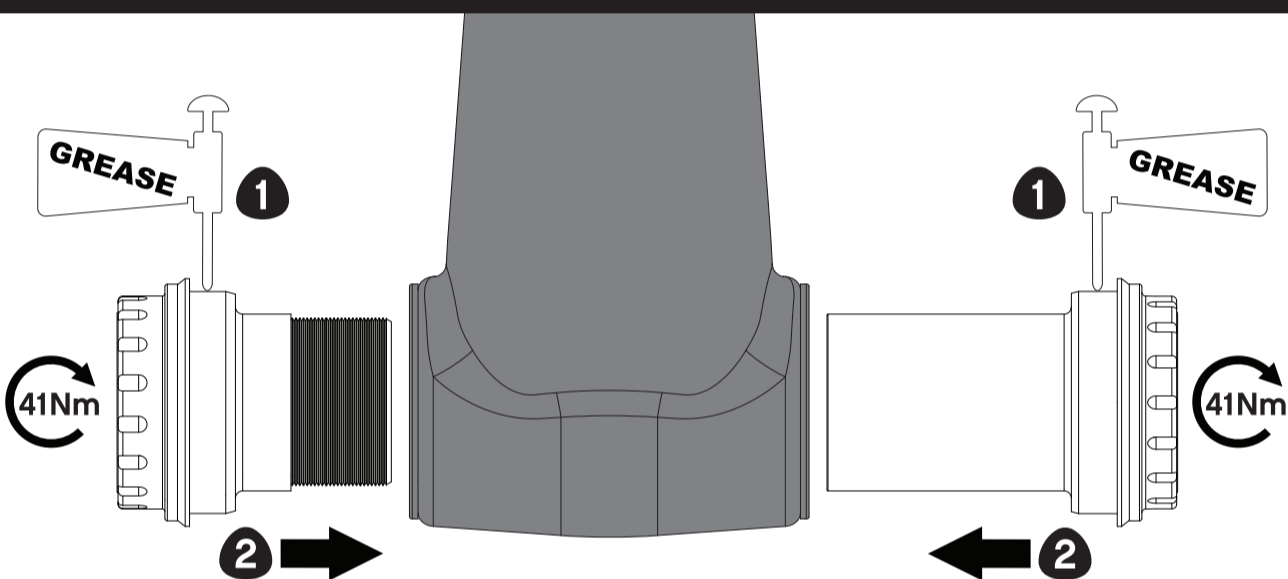

SPINDLE SPACER TABLE* PF30

Crankset	Spindle length	BB shell width	Non-drive side spindle spacer	Drive side spindle spacer
TRS and XCX	113mm	68/73mm	none	none
TRSr Carbon	123mm	68/73mm	none	none
2015+ LG1*	113mm	68/73mm	none	none
2014- LG1*	113mm	68/73mm	1mm	3.5mm
LG1 cranks	123mm	83mm	none	none
LG1r Carbon	138mm	83mm	none	none

BB SPACER CHART BB30/PF30

Crankset	BB shell width	Non-drive side	Drive side
TRS/XCX	68	1x2.5mm	1x2.5mm
TRSr Carbon	73	No Spacer	No Spacer
2015+ LG1*	100	USE 100mm PF30 BB ONLY	
2014- LG1*	68	1x2.5mm	1x2.5mm
LG1 cranks	73	No Spacer	No Spacer
LG1r Carbon	83	1x2.5mm	1x2.5mm

*Cranksets with "1 deg" marked on them are 2015+.

BASE BSA INSTALL

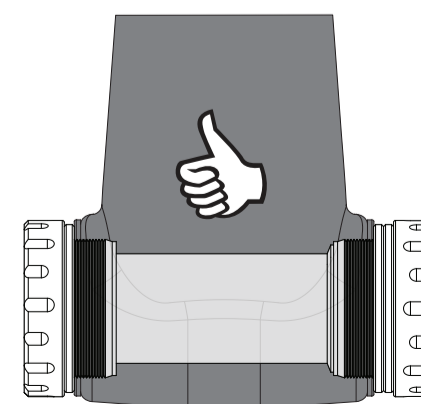
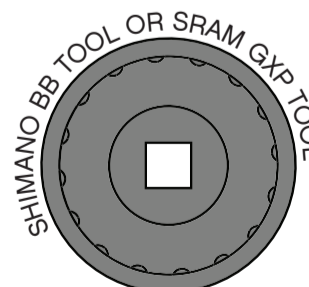
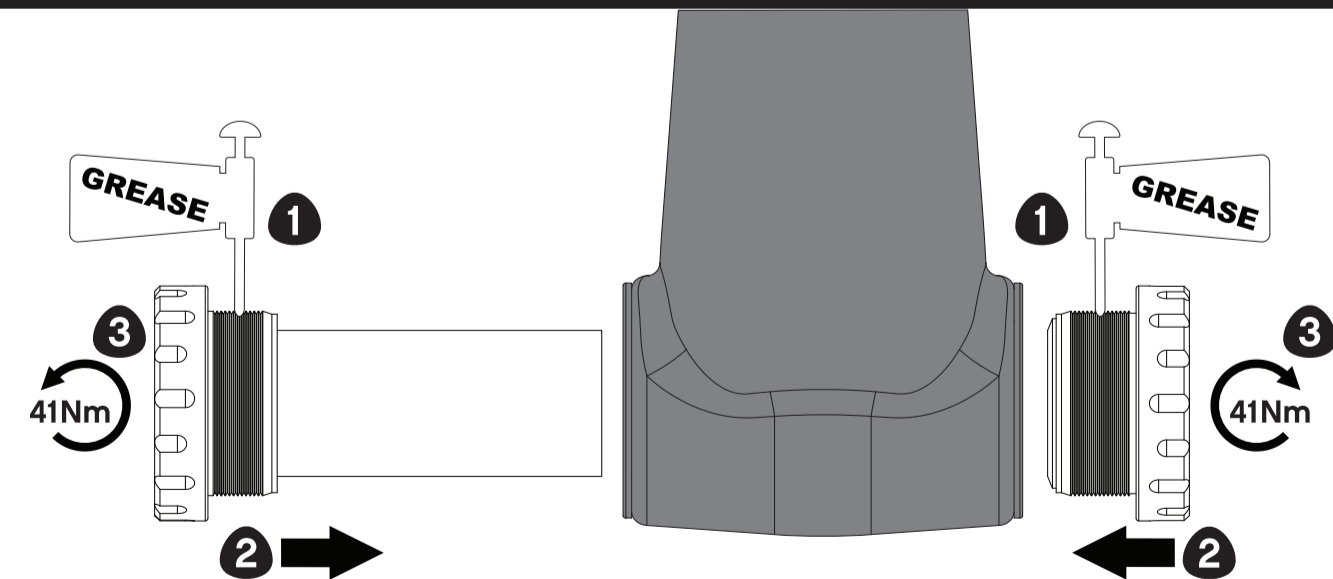

SPINDLE SPACER TABLE* BSA

Crankset	Spindle length	BB shell width	Non-drive side spindle spacer	Drive side spindle spacer
TRS and XCX	113mm	68 or 73mm	none	none
TRSr Carbon	123mm	68 or 73mm	none	none
2015+ LG1*	113mm	68 or 73mm	none	none
2014 and earlier LG1*	113mm	68 or 73mm	1mm	3.5mm
LG1	123mm	83mm	none	none
LG1r Carbon	138mm	83mm	none	none
TRS Fatbike (73mm offset)	145mm	100mm	none	none
TRS Fatbike (78mm offset)	155mm	100mm	5mm	5mm

BB SPACER CHART BSA

Crankset	BB shell width	Non-drive side	Drive side
TRS/XCX	68	1x2.5mm	2x2.5mm
TRSr Carbon	73	No Spacer	1x2.5mm
2015+ LG1*	100	1x2.5mm	2x2.5mm
2014 and earlier LG1*	68	1x2.5mm	2x2.5mm
LG1	73	No Spacer	1x2.5mm
LG1r Carbon	83	1x2.5mm	2x2.5mm

*Cranksets with "1 deg" marked on them are 2015+.