

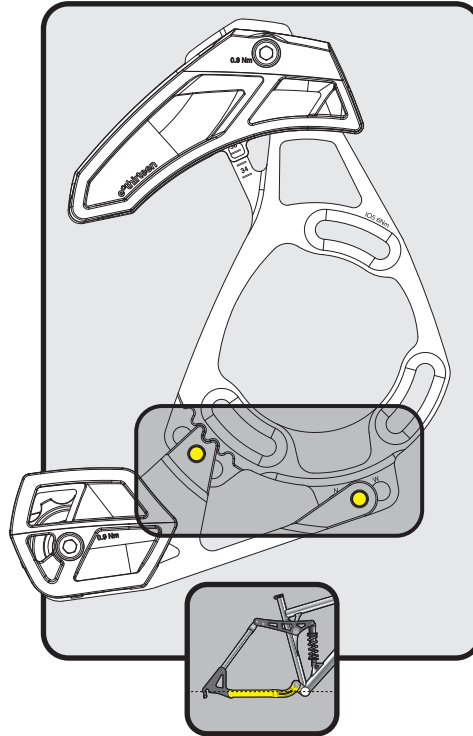

REGULAR POSITION  
(MOST BIKES)

NARROW POSITION  
(MOST HARDTAIL BIKES)

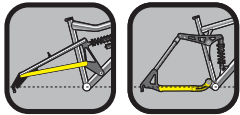
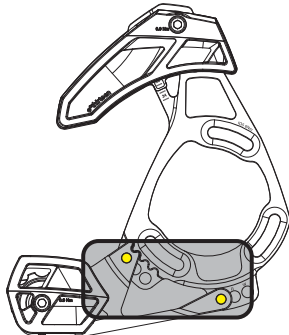

WIDE POSITION  
(DROPPED CHAINSTAY BIKES)

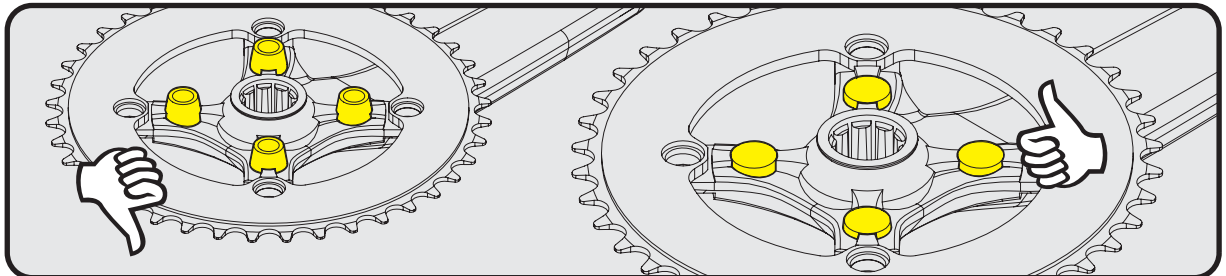
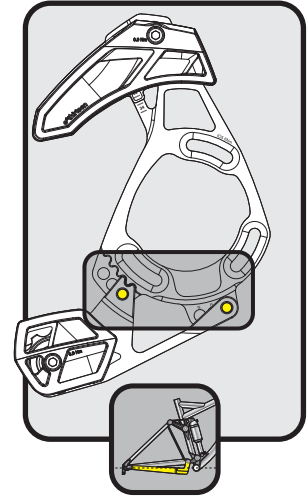



e\*thirteen components



405 East D St, Ste. C  
Petaluma, CA 94952  
1.800.801.9839

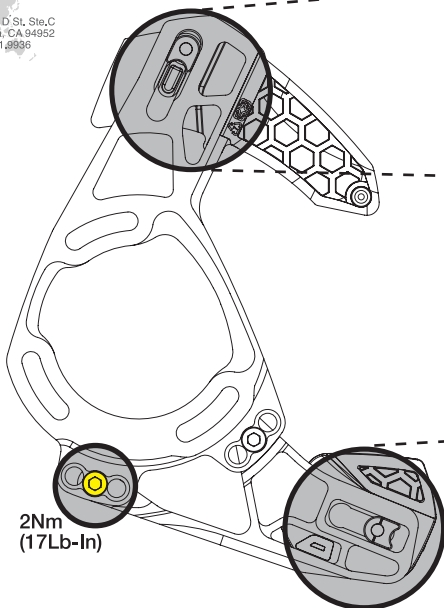

2Nm  
(17Lb-In)

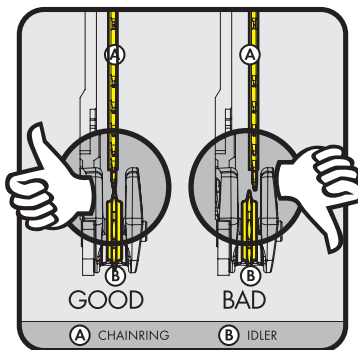
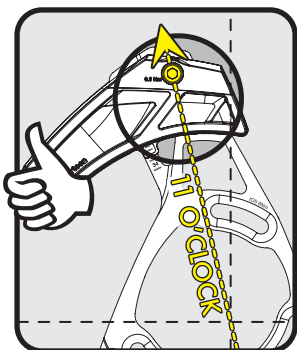
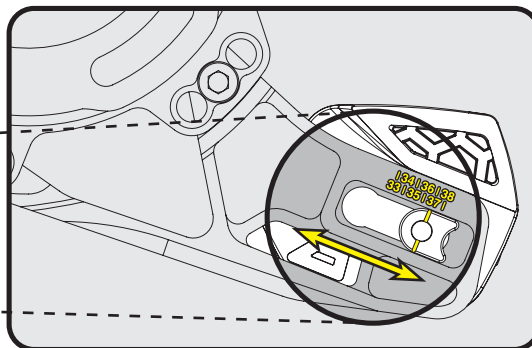
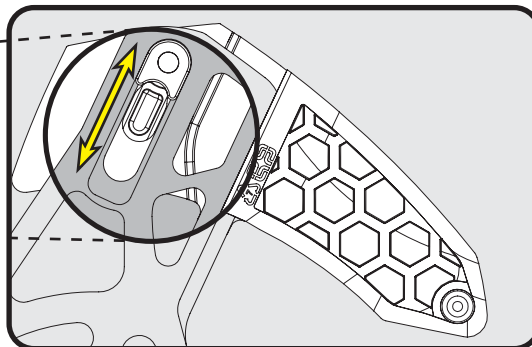

BB SHELL WIDTH	CHAINLINE	TYPICAL BB SPINDLE LENGTH	SPACER WASHERS NEEDED BETWEEN BACKPLATE AND ISCG TAB	
			BLACK (2.5MM)	GOLD (1.25MM)
68	47.5	113	0	FINE TUNE
68 OR 73	50	113	0	FINE TUNE
68 OR 73	52.5	118	1	FINE TUNE
68 OR 73	55	123	2	FINE TUNE
68 OR 73	57.5	128	3	FINE TUNE
83	57.5	128	1	FINE TUNE
83	60	133	2	FINE TUNE

BB MOUNT BACKPLATE - FINE TUNE 0.5MM SPACER x2 INCLUDED  
NO ISCG ADAPTER NEEDED FOR DIRECT MOUNT ISCG 05, ISCG OR BB BACKPLATES

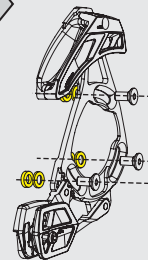

INCLUDED: ( ) LONG BOLTS x3 ( ) SHORT BOLTS x3 ( ) x2 BB 05mm SPACER  
( ) THICK 2.5mm WASHERS x6 ( ) THIN 1.25mm WASHERS X3

\*Do not paint plastics \*Do not use thread lock on any hardware \*Do not use "mineral spirit" based chain lubes