

REGULAR POSITION

(MOST BIKES)

NARROW POSITION

(MOST HARDTAIL BIKES)

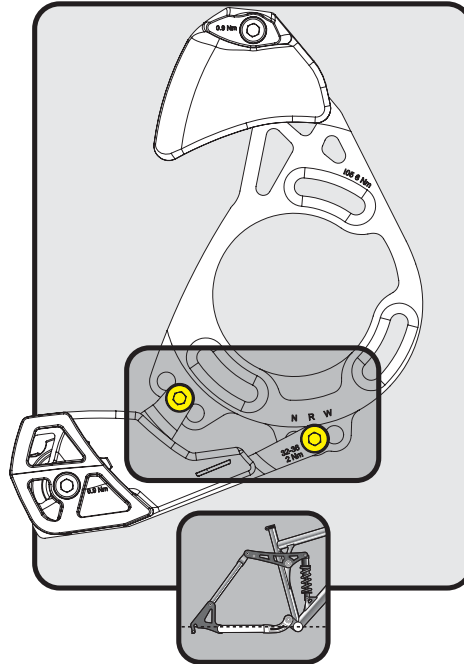
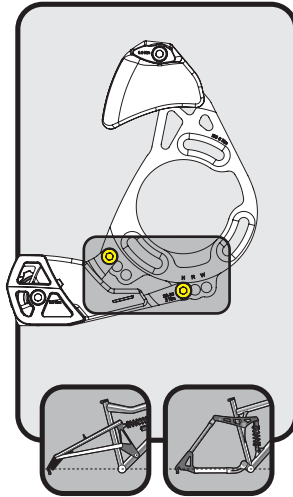

WIDE POSITION

(SOME DH/ALL MOUNTAIN BIKES)

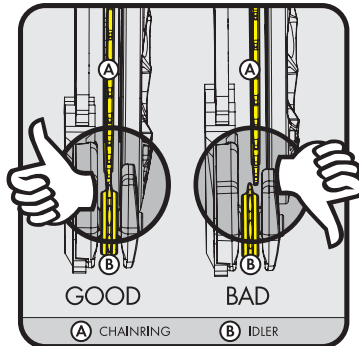
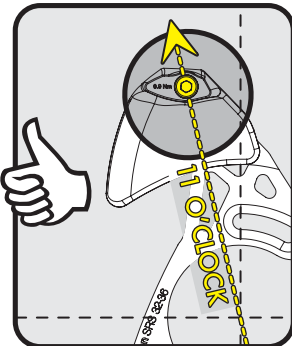
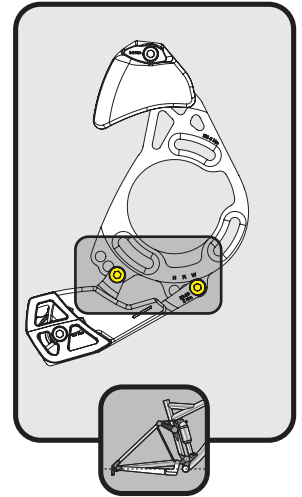

BB SHELL WIDTH	CHAINLINE	TYPICAL BB SPINDLE LENGTH	SPACER WASHERS NEEDED BETWEEN BACKPLATE AND ISCG TAB	
			BLACK (2.5MM)	GOLD (1.25MM)
68	47.5	113	0	FINE TUNE
68 OR 73	50	113	0	FINE TUNE
68 OR 73	52.5	118	1	FINE TUNE
68 OR 73	55	123	2	FINE TUNE
68 OR 73	57.5	128	3	FINE TUNE
83	57.5	128	1	FINE TUNE
83	60	133	2	FINE TUNE
100	63.5	140	0	FINE TUNE
100	65	145	1	FINE TUNE

INCLUDED : (LONG BOLTS x 3) (SHORT BOLTS x 3) (x 1 ISCG ADAPTER)
(THICK 2.5mm WASHERS x 6) (THIN 1.25mm WASHERS x 3)

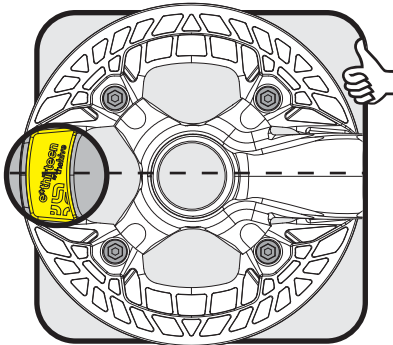
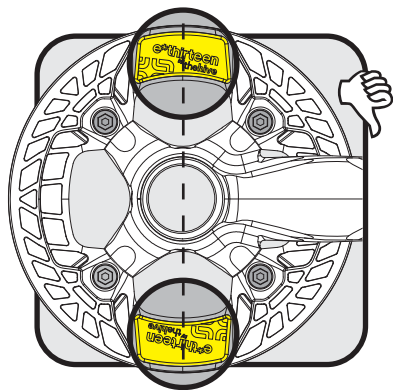

Turbocharger badges
align with crank arm axis

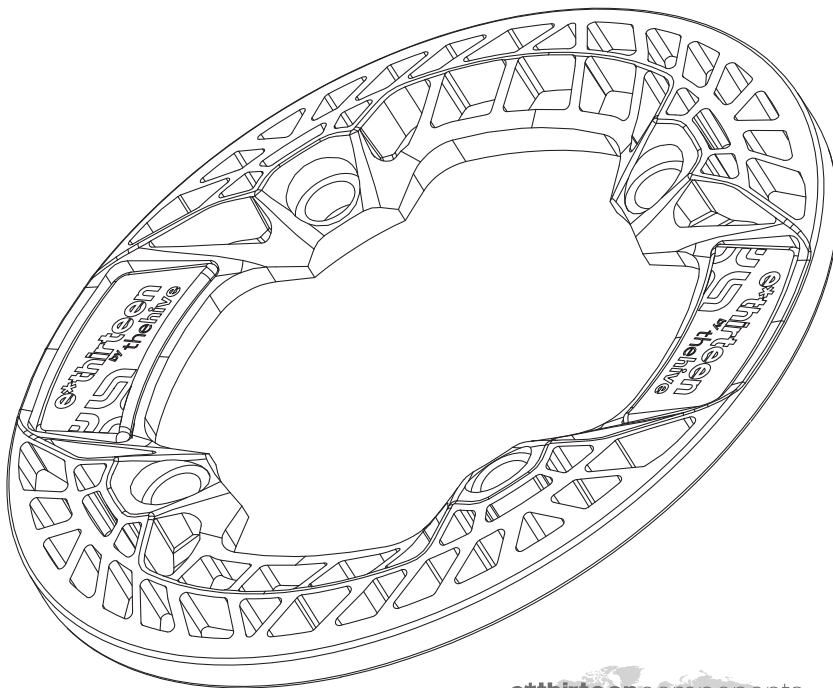

e*thirteen components



405 East D St. Ste.C
Petaluma, CA 94952
1.800.801.9936

The incredibly light, amazingly strong, impact absorbing Turbocharger bashguard.
Another cycling innovation brought to you by e.thirteen components.