



**BB - 34-41Nm (e\*thirteen BB)**



**I05/IOLD - 6Nm**



**NO ISCG  
2 RING**

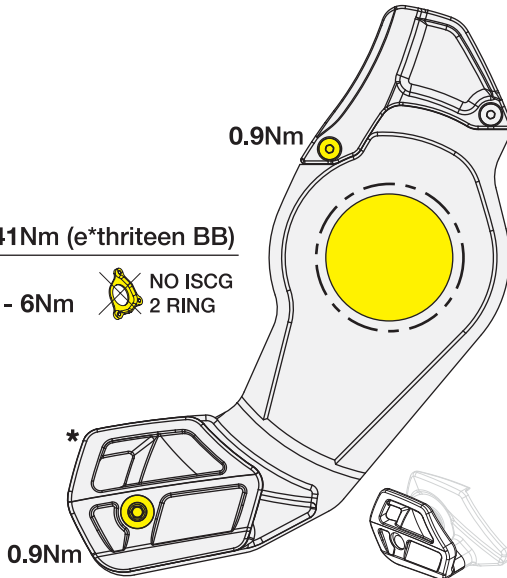

\*

0.9Nm

\* TRS Dual Ring no bashguard lower slider

40T MAX

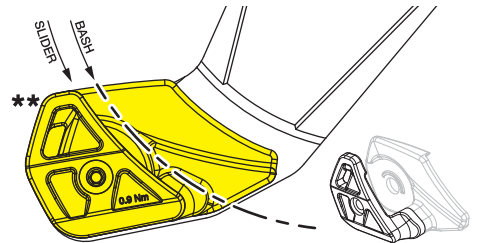

\*\* TRS Dual Ring bashguard lower slider.  
For use with optional bashguard  
(Turbocharger not included)

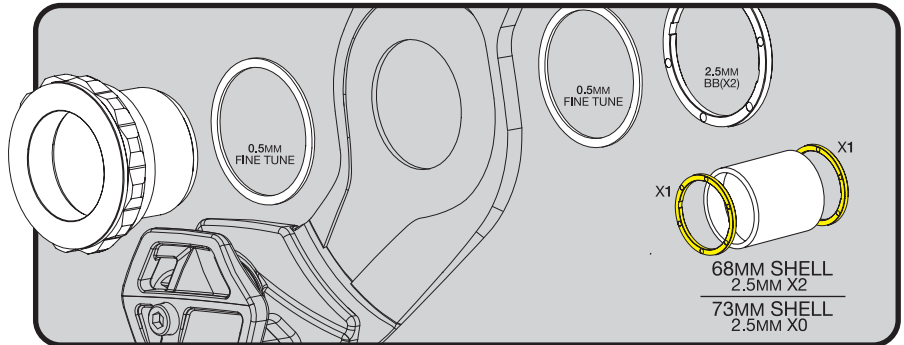
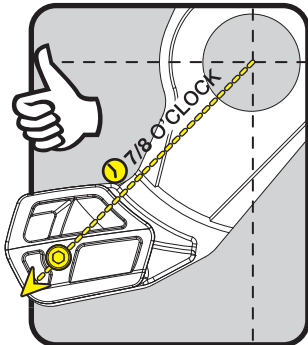

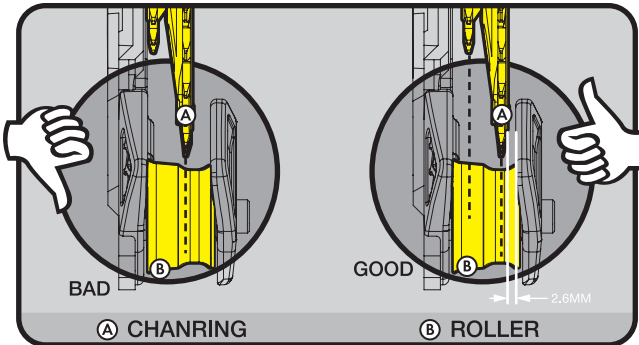
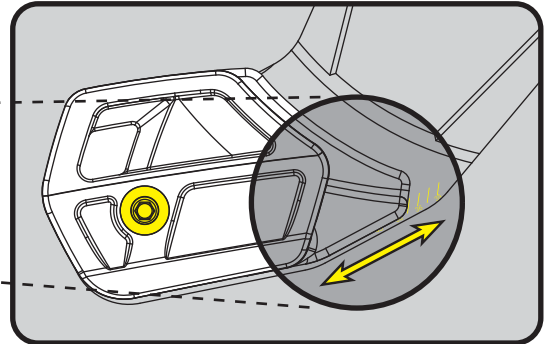
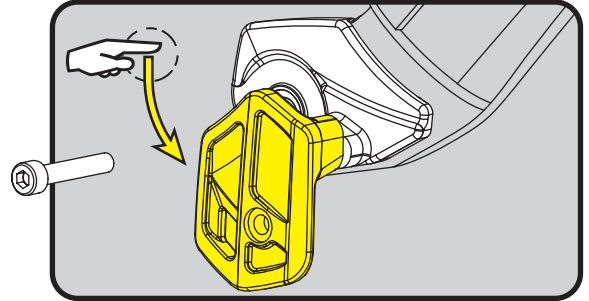
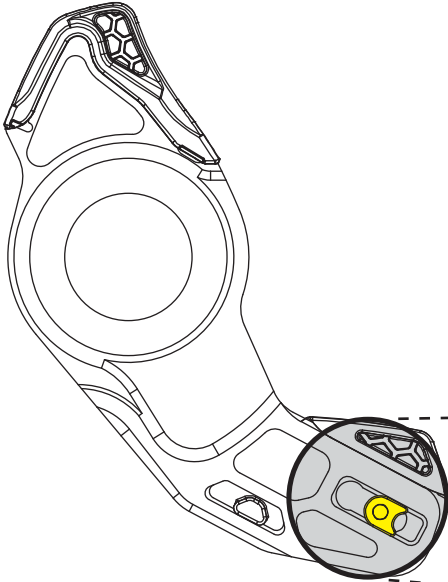

BB SHELL WIDTH	CHANLINE	TYPICAL BB SPINDLE LENGTH	SPACER WASHERS NEEDED BETWEEN BACKPLATE AND ISCG TAB		
			BLACK (2.5MM)	GOLD (1.25MM)	
68	47.5	113	0	FINE TUNE	
68 OR 73	50	113	0	FINE TUNE	
68 OR 73	52.5	118	1	FINE TUNE	
68 OR 73	55	123	2	FINE TUNE	
68 OR 73	57.5	128	3	FINE TUNE	
83	57.5	128	1	FINE TUNE	
83	60	133	2	FINE TUNE	
100	63.5	140	0	FINE TUNE	
100	65	145	1	FINE TUNE	

INCLUDED: ( ) LONG BOLTS x3 ( ) SHORT BOLTS x3 ( ) THICK 2.5mm WASHERS x6 ( ) THIN 1.25mm WASHERS X3 ( ) x2 BB 0.5mm SPACER