

1

FOR TRS/LG1 CRANKS WITH CHAINLINE ADJUSTMENT

142MM/148MM FRAMES: Use **SL Chainring** (-8mm offset).
157MM FRAMES: Use **UL Chainring** (-5mm offset).

FOR XCX CRANKS WITHOUT CHAINLINE ADJUSTMENT

142MM GRAVEL FRAMES: Use **UL Chainring** (-5mm offset).
148MM MTBFRAMES: Use **UL Chainring** (-5mm offset).

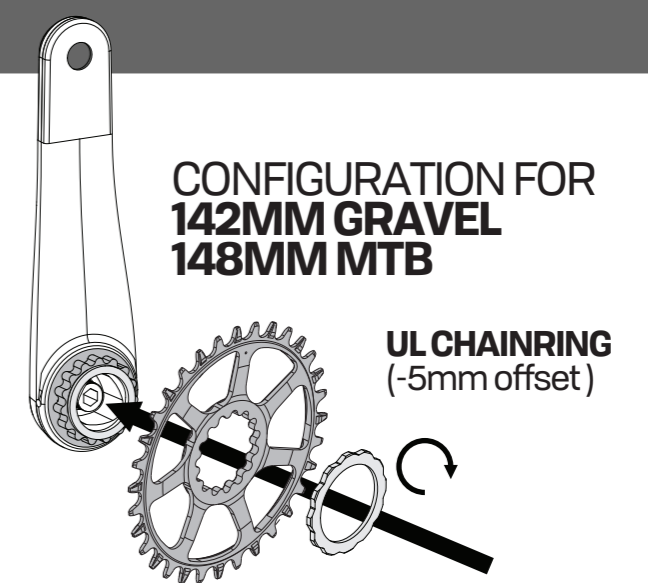
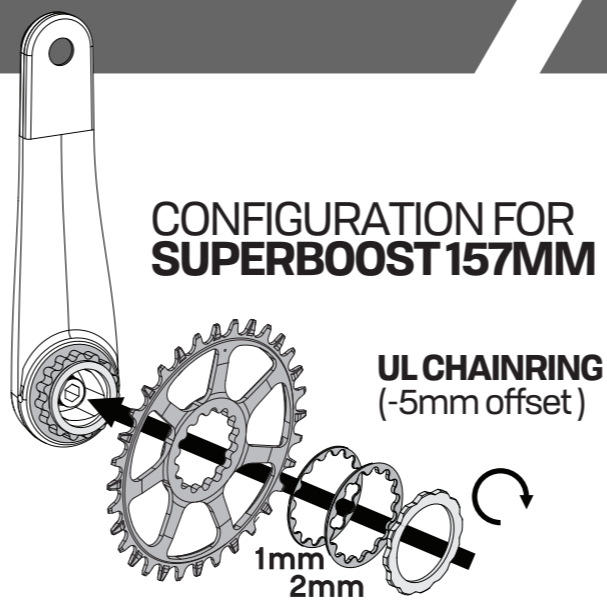
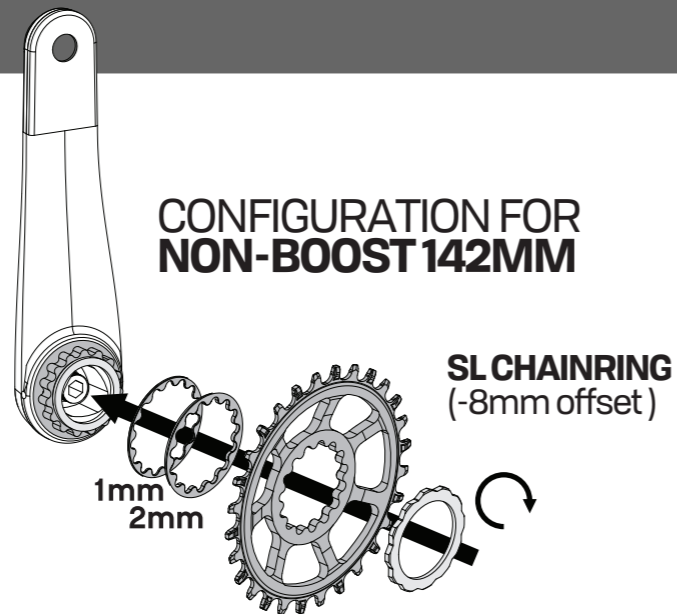

2

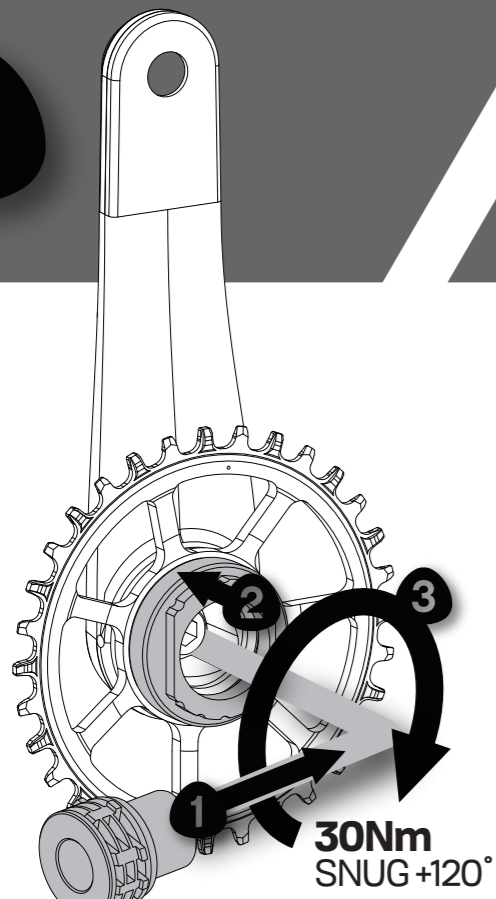

INSERT NYLON PLUG INTO CRANK POLYGON, THEN PLACE LOCKRING TOOL ON TOP AND TIGHTEN LOCKRING OVER CHAINRING.

3

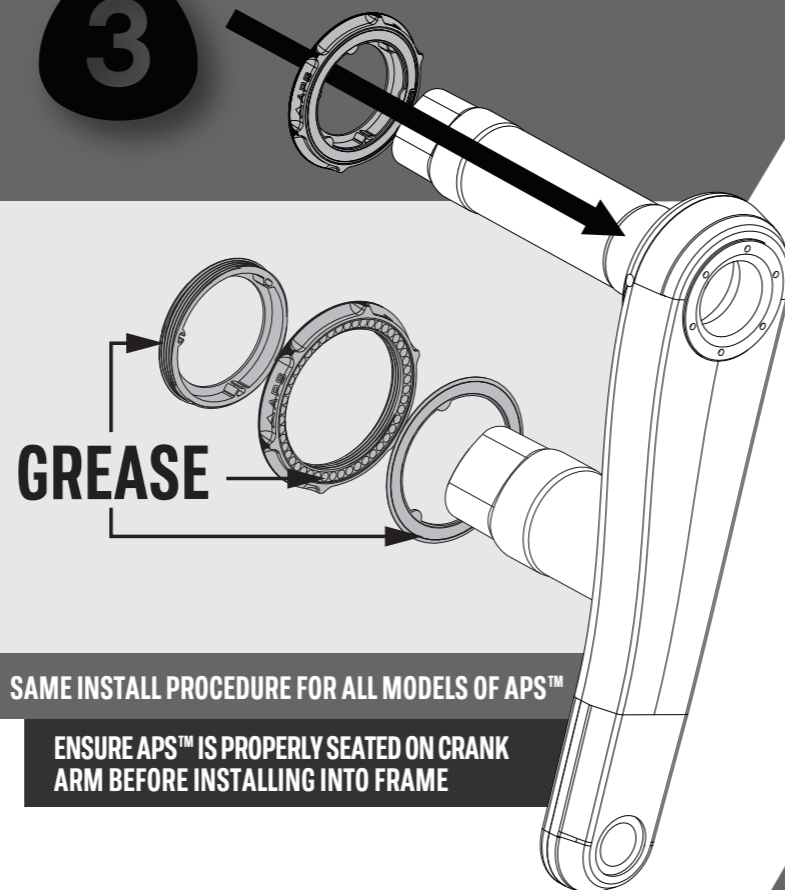

4

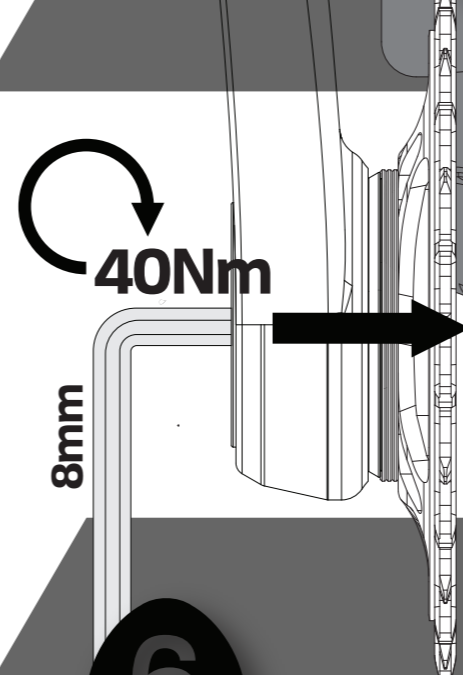

5

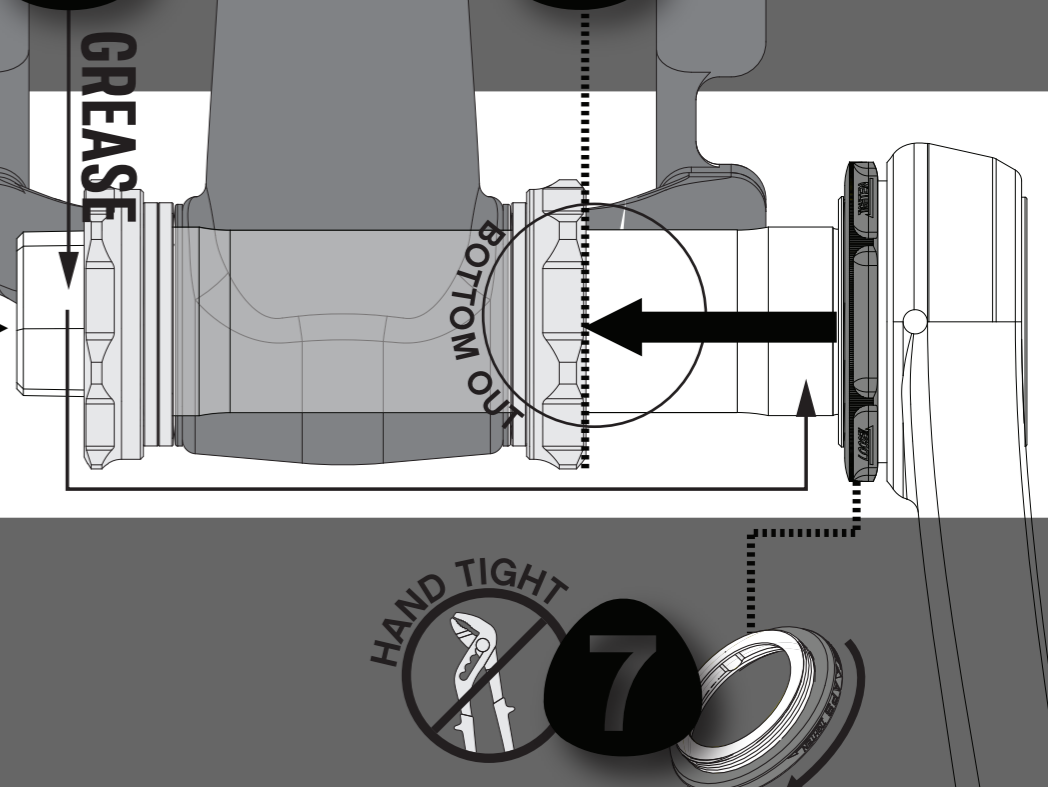

HAND TIGHT

e*thirteen MTB BOTTOM BRACKET INSTALLATION

BB92 INSTALL

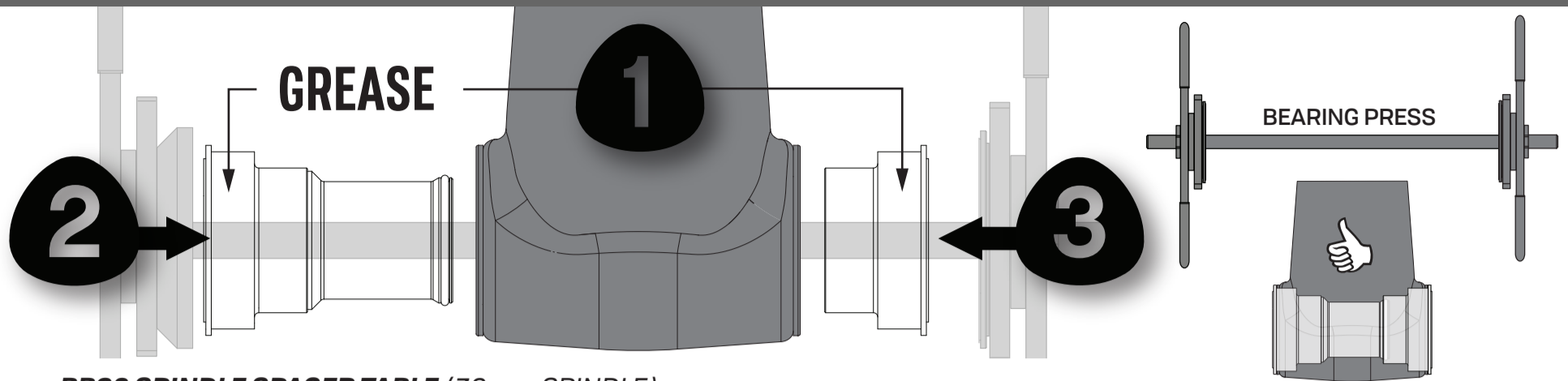

BB92 SPINDLE SPACER TABLE (30mm SPINDLE)

CRANKSET	BB SHELL WIDTH	NON-DRIVE SIDE SPINDLE SPACERS	DRIVE SIDE SPINDLE SPACERS
All e*thirteen cranks	92mm or 107mm	0.5mm	0.5mm

BB92 SPINDLE SPACER TABLE (24mm SPINDLE)

CRANKSET	BB SHELL WIDTH	NON-DRIVE SIDE SPINDLE SPACERS	DRIVE SIDE SPINDLE SPACERS
All e*thirteen cranks	92mm or 107mm	NONE	NONE

IF AFTER TIGHTENING APS™ THERE IS STILL SPACE/GAPS IN THE ASSEMBLY, USE SPINDLE SPACERS TO FIX THE ISSUE.

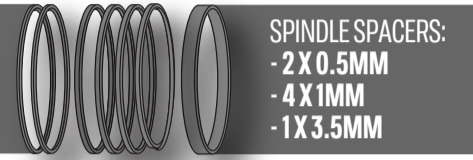

SPINDLE SPACERS:
- 2 X 0.5MM
- 4 X 1MM
- 1 X 3.5MM

PF30 INSTALL

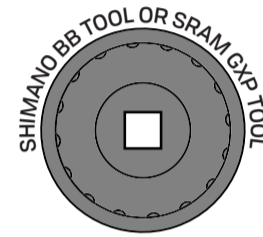
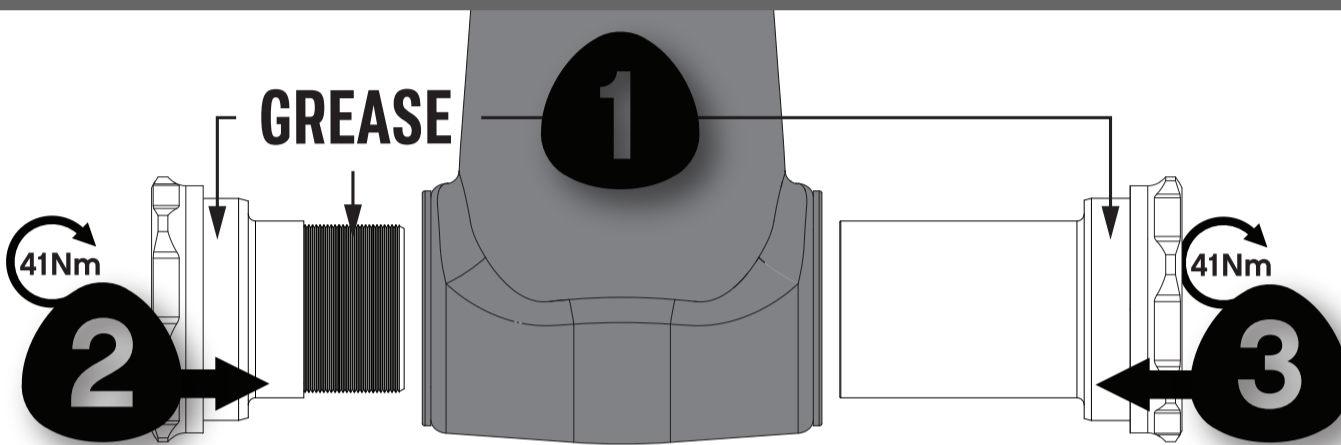

BASE CRANKS & BB
24MM SPINDLE



PLUS/RACE CRANKS & BB
30MM SPINDLE

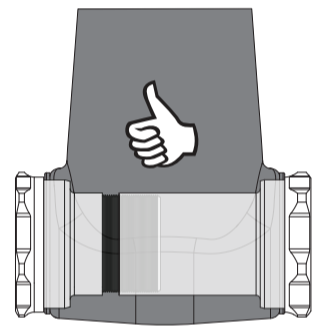
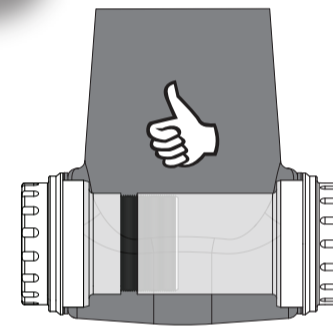

PF30 & BB30 (24/30mm SPINDLE, 2x BB Shell Spacers in Packaging)

CRANKSET	BB SHELL WIDTH	NON-DRIVE SIDE BB SHELL SPACERS	DRIVE SIDE BB SHELL SPACERS
XCX, TRS, LG1	68mm	1 x 2.5mm	1 x 2.5mm
XCX, TRS, LG1	73mm	none	none
LG1	83mm	1 x 2.5mm	1 x 2.5mm

PF30 & BB30 (24/30mm SPINDLE, 3x BB Shell Spacers in Packaging)

CRANKSET	BB SHELL WIDTH	NON-DRIVE SIDE BB SHELL SPACERS	DRIVE SIDE BB SHELL SPACERS
XCX, TRS, LG1	68mm	1 x 2.5mm	2 x 2.5mm
XCX, TRS, LG1	73mm	none	1 x 2.5mm
LG1	83mm	1 x 2.5mm	2 x 2.5mm

PF30 Fatbike (24/30mm SPINDLE)

CRANKSET	SPINDLE LENGTH	BB SHELL WIDTH	NON-DRIVE SIDE SPINDLE SPACERS	DRIVE SIDE SPINDLE SPACERS
TRS Fatbike 73mm offset	145mm	100mm	2.5mm	2.5mm
TRS Fatbike 83mm offset	155mm	100mm	7.5mm (2.5mm + 5mm)	7.5mm (2.5mm + 5mm)m

BSA INSTALL

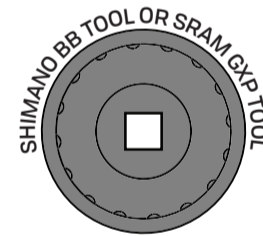
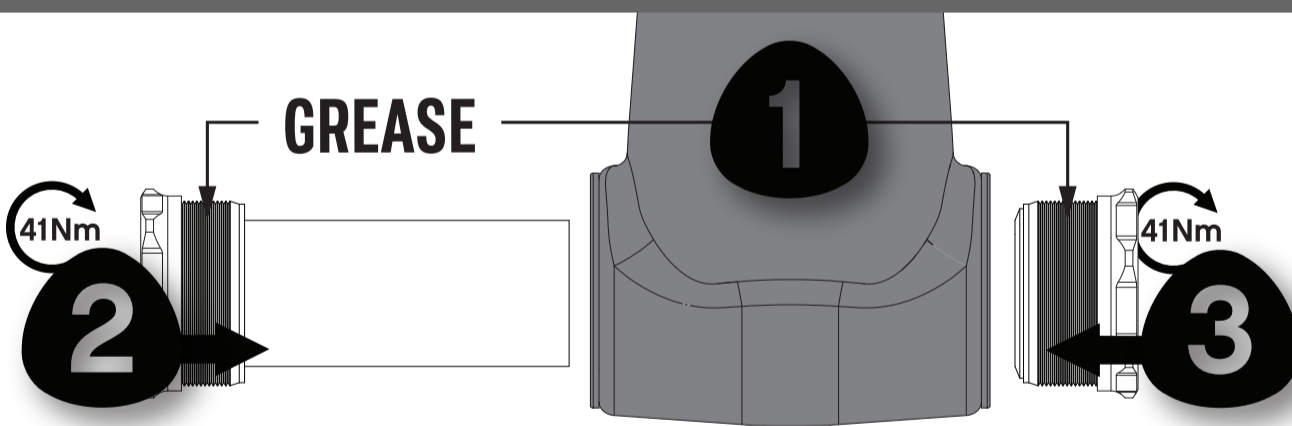

BASE CRANKS & BB
24MM SPINDLE



PLUS/RACE CRANKS & BB
30MM SPINDLE

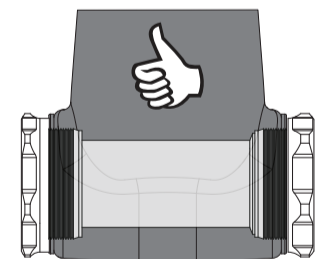
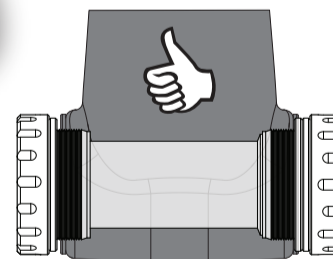

BSA (24/30mm SPINDLE)

CRANKSET	BB SHELL WIDTH	NON-DRIVE SIDE BB SHELL SPACERS	DRIVE SIDE BB SHELL SPACERS
XCX, TRS, or LG1	68mm	1 x 2.5mm	2 x 2.5mm
XCX, TRS, or LG1	73mm	none	1 x 2.5mm
LG1	83mm	1 x 2.5mm	2 x 2.5mm

T47 INSTALL

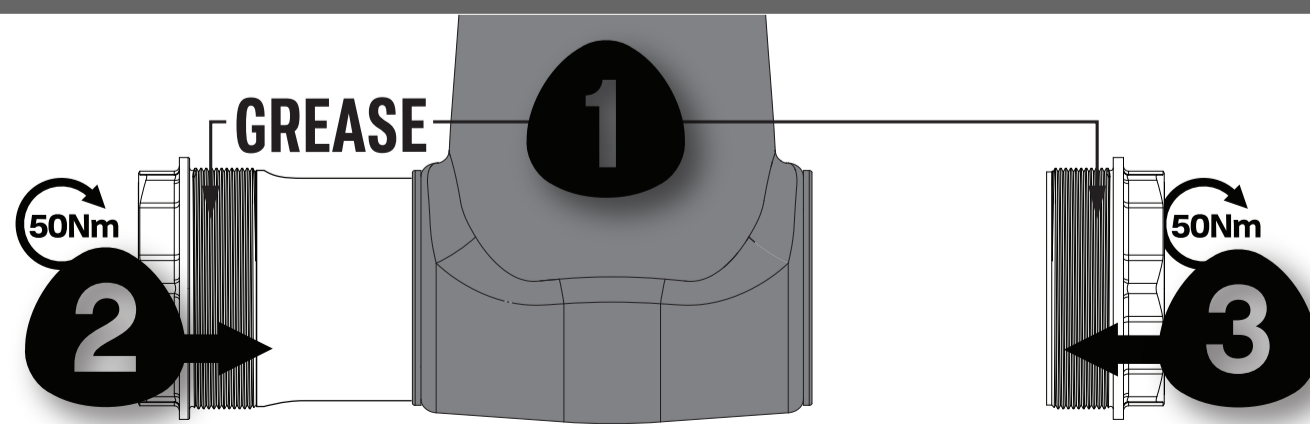

PLUS/RACE CRANKS & BB
30MM SPINDLE

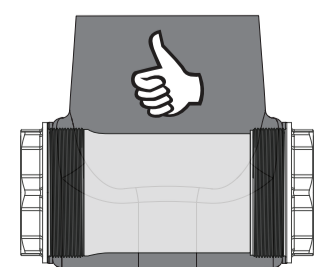

T47 (30mm SPINDLE)

CRANKSET	BB SHELL WIDTH	NON-DRIVE SIDE BB SHELL SPACERS	DRIVE SIDE BB SHELL SPACERS
XCX	68mm	none	none
XCX	73mm	none	1 x 2.5mm

e*thirteen XCX GRAVEL BOTTOM BRACKET INSTALLATION

BB92 INSTALL

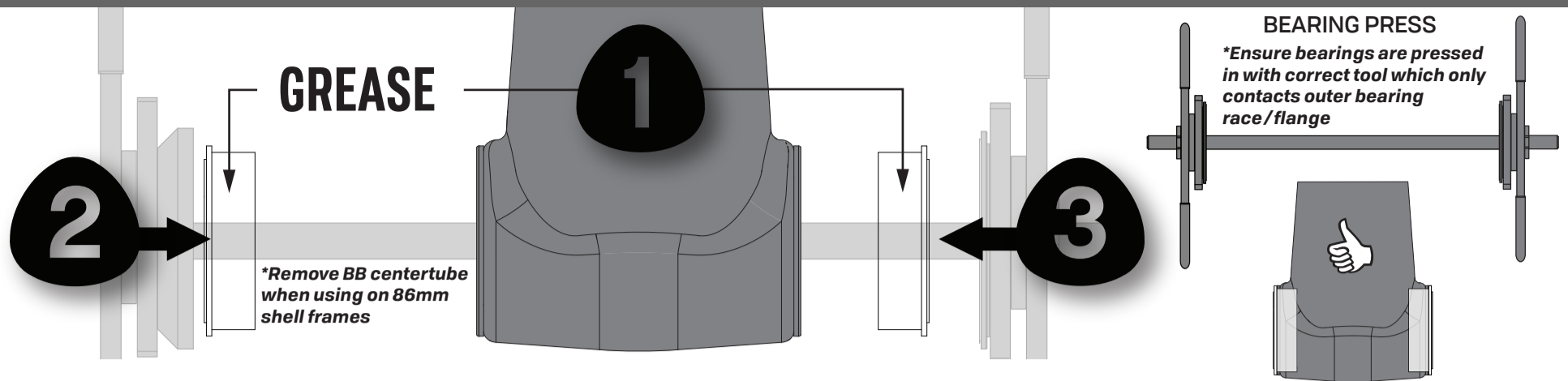

BB92 SPINDLE SPACER TABLE (30mm SPINDLE)

CRANKSET	BB SHELL WIDTH	NON-DRIVE SIDE SPINDLE SPACERS	DRIVE SIDE SPINDLE SPACERS
XCX Gravel	86mm	0.5mm	0.5mm

IF AFTER TIGHTENING APS™ THERE IS STILL SPACE/GAPS IN THE ASSEMBLY, USE SPINDLE SPACERS TO FIX THE ISSUE.

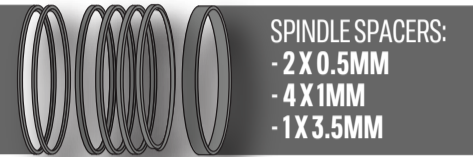

PF30 INSTALL

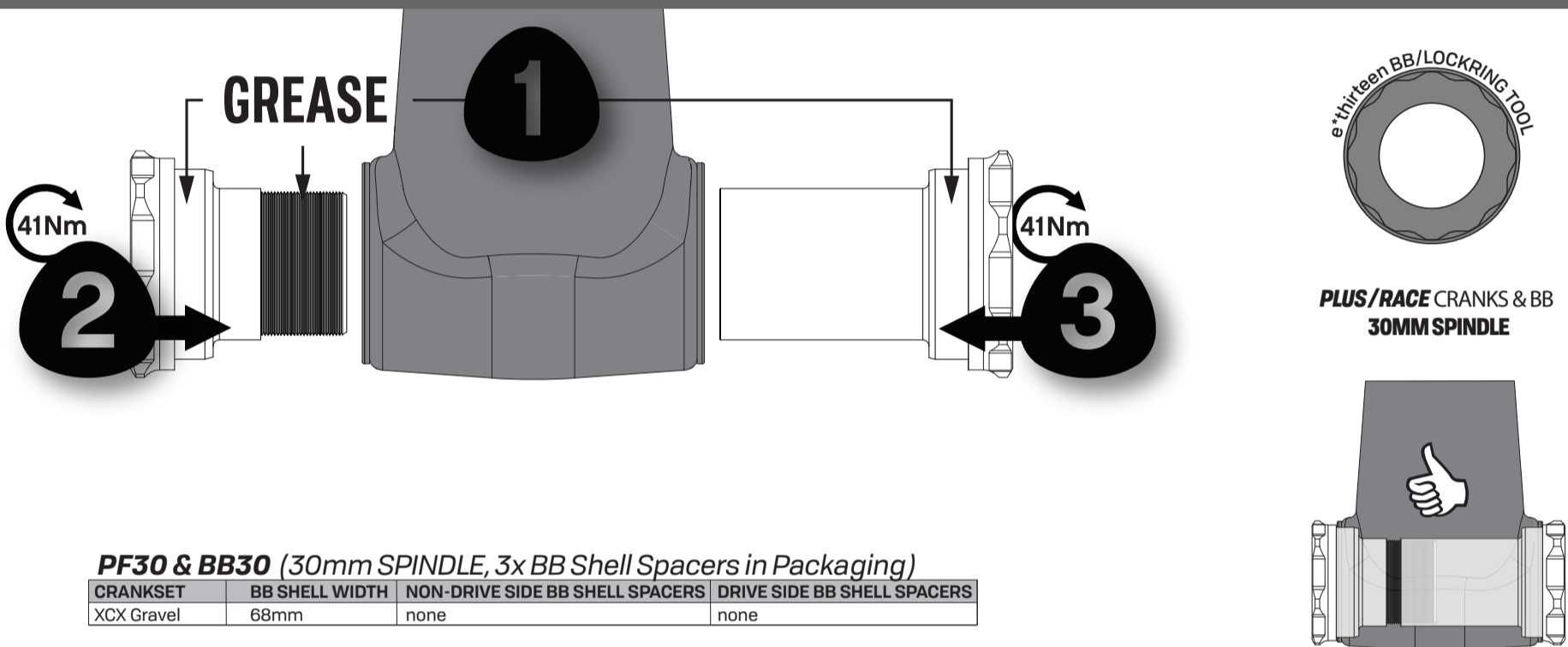

PF30 & BB30 (30mm SPINDLE, 3x BB Shell Spacers in Packaging)

CRANKSET	BB SHELL WIDTH	NON-DRIVE SIDE BB SHELL SPACERS	DRIVE SIDE BB SHELL SPACERS
XCX Gravel	68mm	none	none

BSA INSTALL

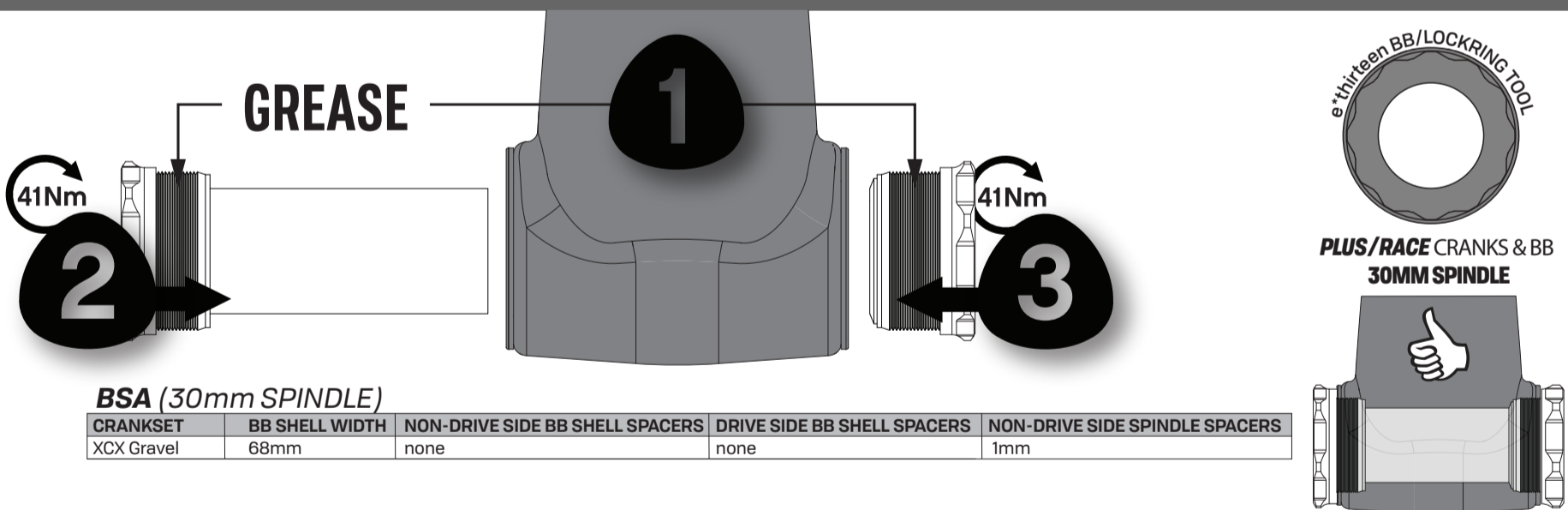

BSA (30mm SPINDLE)

CRANKSET	BB SHELL WIDTH	NON-DRIVE SIDE BB SHELL SPACERS	DRIVE SIDE BB SHELL SPACERS	NON-DRIVE SIDE SPINDLE SPACERS
XCX Gravel	68mm	none	none	1mm

T47 INSTALL

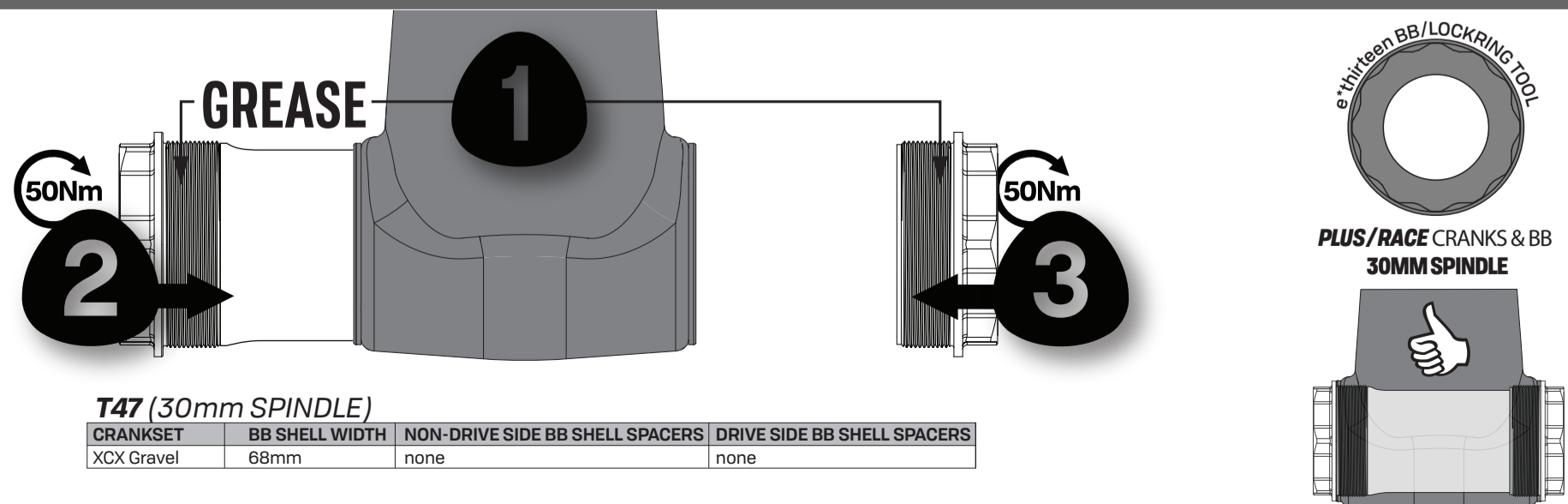

T47 (30mm SPINDLE)

CRANKSET	BB SHELL WIDTH	NON-DRIVE SIDE BB SHELL SPACERS	DRIVE SIDE BB SHELL SPACERS
XCX Gravel	68mm	none	none